

Parts Manual

1. Casting mechanism

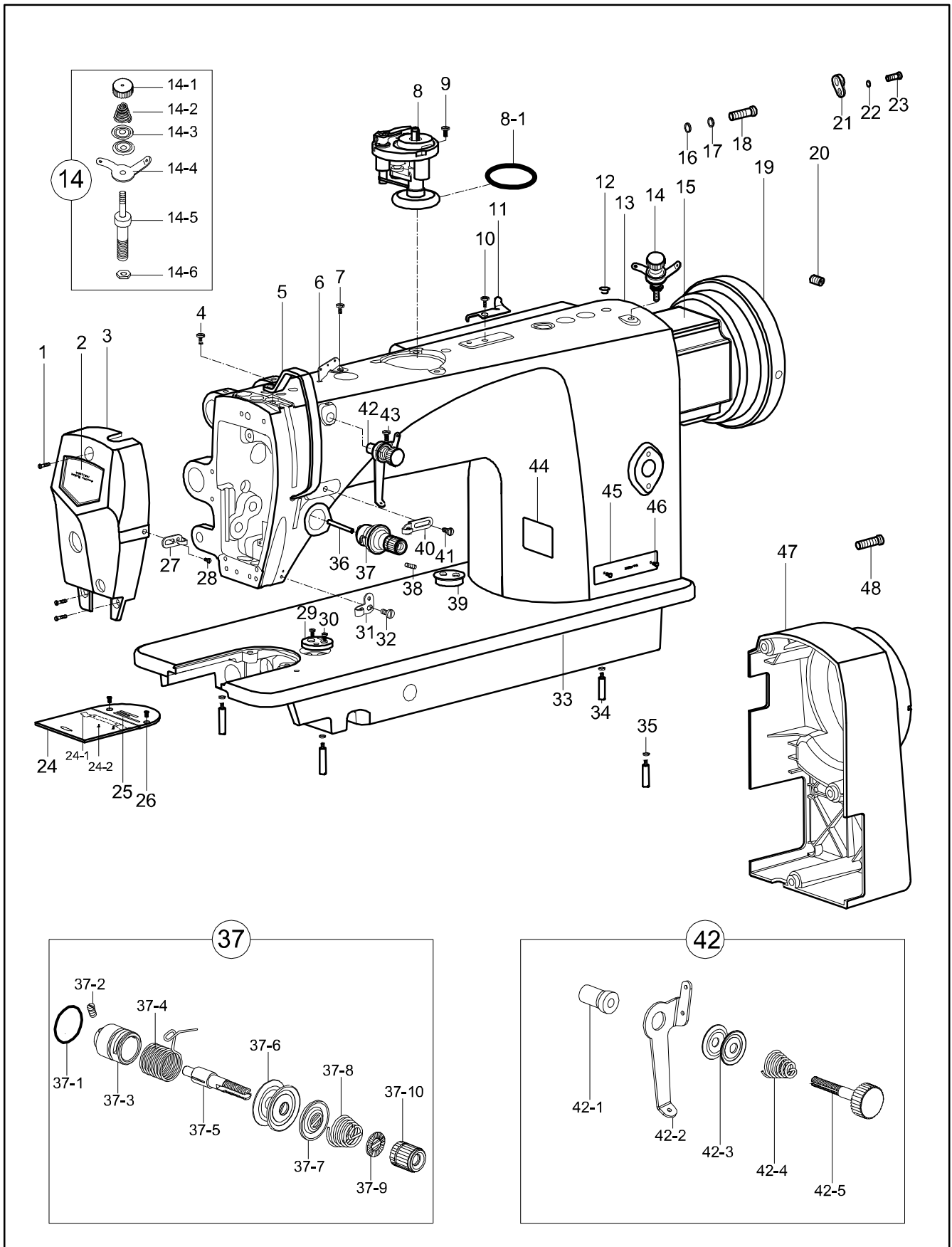

1. Casting mechanism

NO.	PartNumber	Name	Qty		Remark
			WF3955DD	WF3955AUT	
1	G09-1-1	Screw	3	3	
2	G09-1-2	Face plate	1	1	
3	G09-1-3	Face plate asm.	1	*	
	G10-1-3	Face plate asm.	*	1	
4	G09-1-4	Screw	1	1	
5	G09-1-5	Cover	1	1	
6	G09-1-6	Thread retainer	1	1	
7	G09-1-7	Screw	1	1	
8	G09-1-8	Bobbin winder	1	1	
(8-1)	G09-1-8-1	Rubber ring	1	1	
9	G09-1-9	Screw	3	3	
10	G09-1-10	Screw	1	1	
11	G09-1-11	Cutter	1	1	
12	G09-1-12	Rubber plug	1	1	Φ 8. 8
13	G09-1-13	Arm	1	*	
	G10-1-13	Arm	*	1	
14	G09-1-14	Bobbin thread tension	1	1	
(14-1)	G09-1-14-1	Tension nut	1	1	
(14-2)	G09-1-14-2	Tension spring	1	1	
(14-3)	G09-1-14-3	Thread tension disk presser	2	2	
(14-4)	G09-1-14-4	Thread tension guide	1	1	
(14-5)	G09-1-14-5	Tension post	1	1	
(14-6)	G09-1-14-6	Tension nut	1	1	
15	G09-1-15	Motor asm.	1	*	550W
	G09-1-15	Motor asm.	*	1	750W
16	G09-1-15	Washer	4	4	
17	G09-1-15	Spring washer	4	4	
18	G09-1-15	Screw	4	4	
19	G09-1-15	Hand wheel	1	1	
20	G09-1-15	Screw	2	2	
21	G10-1-21	Magnets	*	1	
22	G10-1-22	Magnets washer	*	1	
23	G10-1-23	Screw	*	1	
24	G09-1-24	Slide plate assy	1	1	
(24-1)	G09-1-24-1	Spring plate	1	1	
(24-2)	G09-1-24-2	Screw	2	2	
25	G09-1-25	Needle plate	1	1	
26	G09-1-26	Screw	2	2	
27	G09-1-27	Thread guide	1	1	
28	G09-1-28	Screw	1	1	

1. Casting mechanism

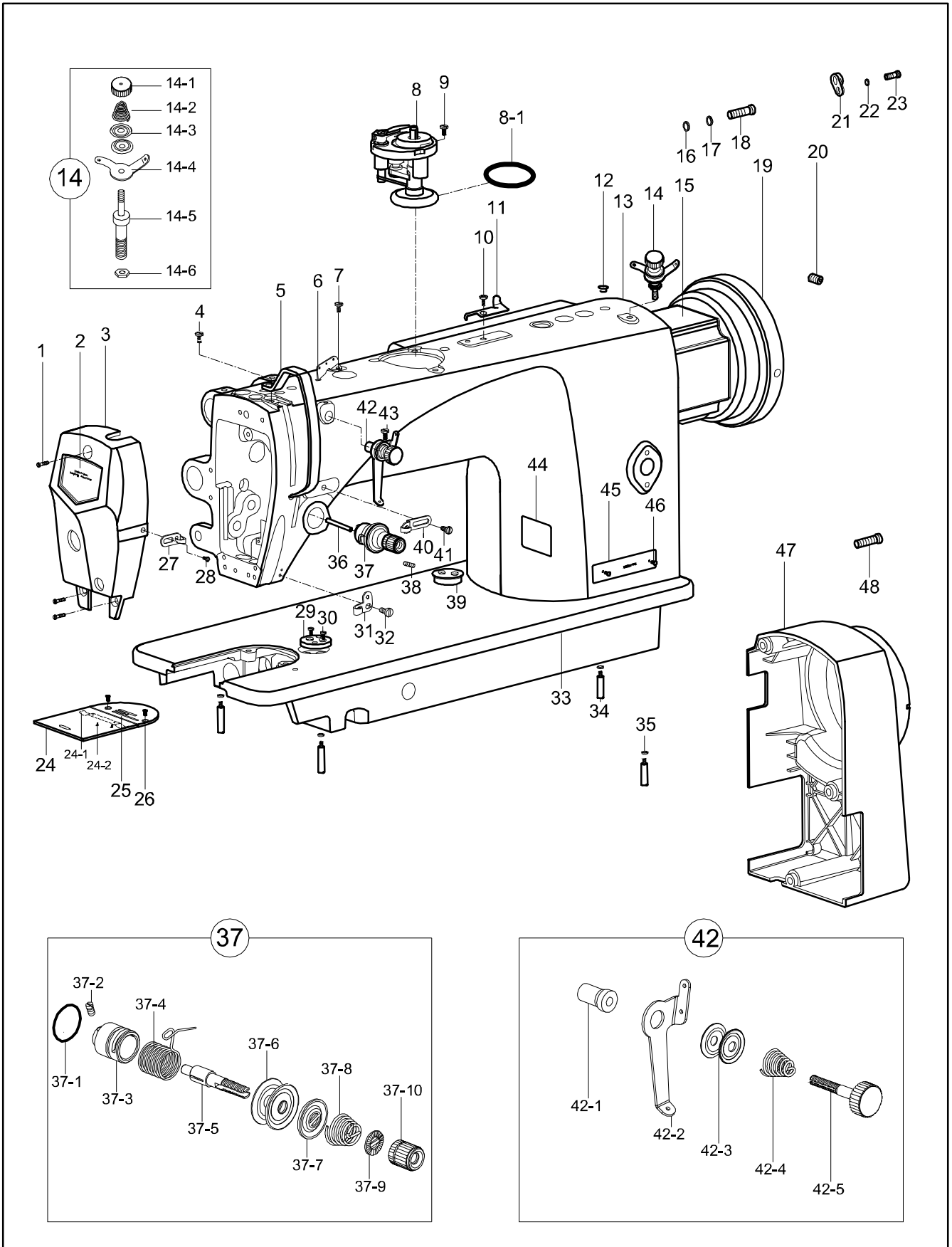

1. Casting mechanism

NO.	PartNumber	Name	Qty		Remark
			WF3955DD	WF3955AUT	
29	G09-1-29	Ruler plate	1	1	
30	G09-1-30	Screw	2	2	
31	G09-1-31	Thrad guide	1	1	
32	G09-1-32	Screw	1	1	
33	G09-1-33	Bed	1	*	
	G10-1-33	Bed	*	1	
34	G09-1-34	Bed leg	4	4	
35	G09-1-35	Washer, spring	4	4	
36	G09-1-36	Tension release pin	1	1	
37	G09-1-37	Thread tension	1	1	
(37-1)	G09-1-37-1	0 ring	1	1	
(37-2)	G09-1-37-2	Set screw	1	1	
(37-3)	G09-1-37-3	Thread tension bracket	1	1	
(37-4)	G09-1-37-4	Thrad take-up spring	1	1	
(37-5)	G09-1-37-5	Tension stud	1	1	
(37-6)	G09-1-37-6	Disc, tension	2	2	
(37-7)	G09-1-37-7	Disc, presser	1	1	
(37-8)	G09-1-37-8	Tension spring	1	1	
(37-9)	G09-1-37-9	Stopper	1	1	
(37-10)	G09-1-37-10	Tension nut	1	1	
38	G09-1-38	Set screw	1	1	
39	G09-1-39	Magnet cord rubber	1	1	
40	G09-1-40	Thrad guide	1	1	
41	G09-1-41	Screw	1	1	
42	G09-1-42	Screw	1	1	
(42-1)	G09-1-42-1	Tension disc	1	1	
(42-2)	G09-1-42-2	Thrad guide	1	1	
(42-3)	G09-1-42-3	Pre-tension stud	2	2	
(42-4)	G09-1-42-4	Tension spring	1	1	
(42-5)	G09-1-42-5	Adjusting screw	1	1	
43	G09-1-43	Set screw	1	1	
44	G09-1-44	Safetv label	1	1	
45	G09-1-45	Model plat	1	*	
	G10-1-45	Model plat	*	1	
46	G09-1-46	Pole	2	2	GB827-86 2.5*5
47	G09-1-47	Motor cover	1	*	
	G10-1-47	Motor cover	*	1	
48	G09-1-48	Screw	3	3	

2. Needle bar and thread take-up mechanism

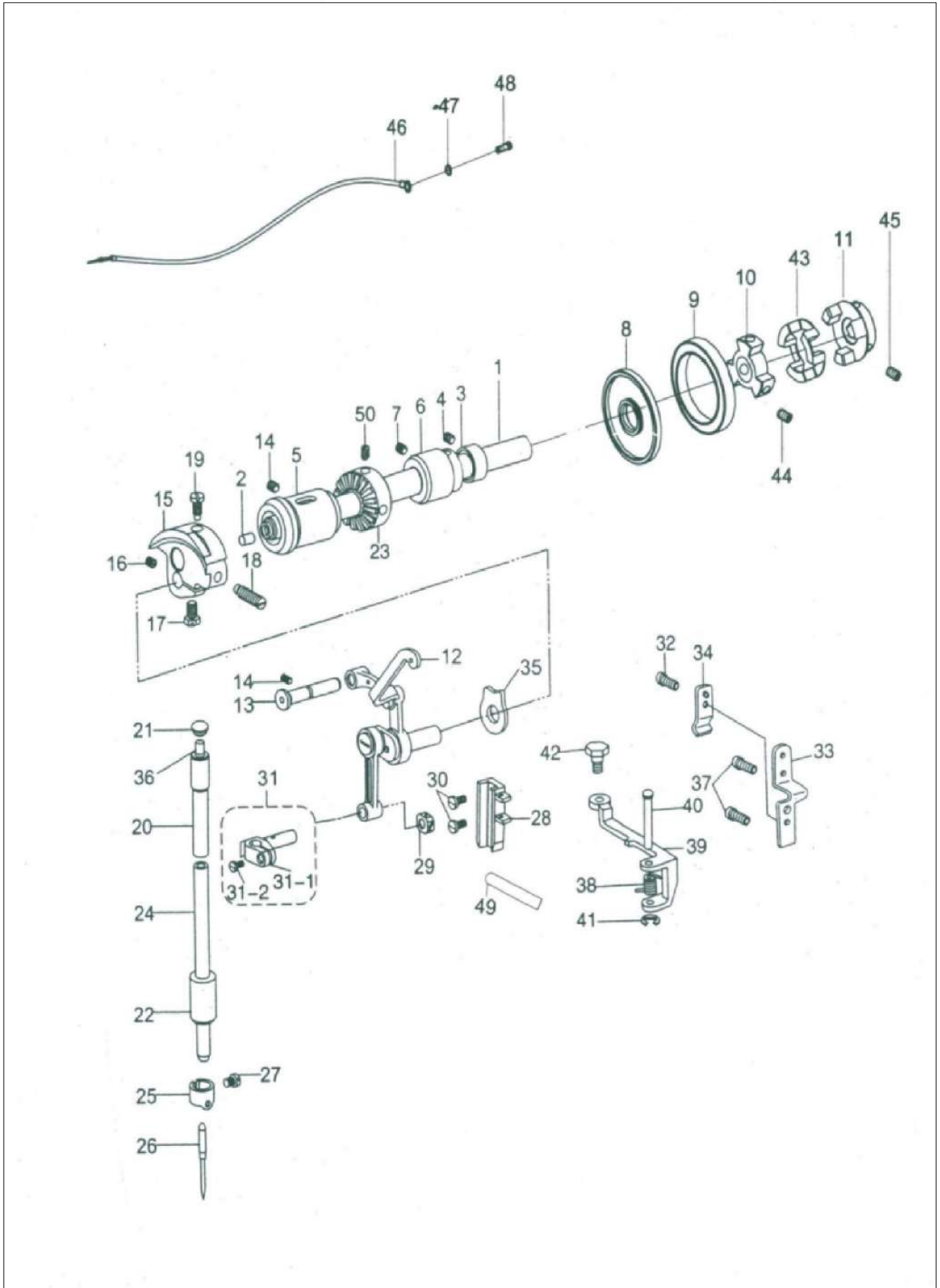

2. Needle bar and thread take-up mechanism

NO.	PartNumber	Name	Qty		Remark
			WF3955DD	WF3955AUT	
1	G09-2-1	Upper shaft	1	1	
2	G09-2-2	Rubber cap	1	1	
3	G09-2-3	Collar	1	1	
4	G09-2-4	Screw	2	2	
5	G09-2-5	Bush, L	1	1	
6	G09-2-6	Bush, M	1	1	
7	G09-2-7	Set screw	1	1	
8	G09-2-8	Bush, R	1	1	
9	G09-2-9	Oil seal	1	1	
10	G09-2-10	Connect block A	1	1	
11	G09-2-11	Connect block B	1	1	
12	G09-2-12	Thread take-up lever set	1	1	
13	G09-2-13	Support shaft	1	1	
14	G09-2-14	Set screw	1	1	
15	G09-2-15	Thread take-up crank	1	1	
16	G09-2-16	Screw	1	1	
17	G09-2-17	Screw	1	1	
18	G09-2-18	Screw	1	1	
19	G09-2-19	Screw	1	1	Φ8.8
20	G09-2-20	Bush, U	1	1	
21	G09-2-21	Rubber cap	1	1	
22	G09-2-22	Bush, D	1	1	
23	G09-2-23	Friction wheel	1	1	
24	G09-2-24	Needle bar	1	1	
25	G09-2-25	Thread guide	1	1	
26	G09-2-26	Needle	1	1	DP*17 23#
27	G09-2-27	Set screw	1	1	
28	G09-2-28	Guide	*	1	
29	G09-2-29	Slide block	1	1	
30	G09-2-30	Screw	*	2	
31	G09-2-31	Needle bar clamp assy	1	1	
(31-1)	G09-2-31-1	Needle bar clamp	1	1	
(31-2)	G09-2-31-2	Set screw	1	1	
32	G10-2-32	Screw	*	1	
33	G10-2-33	Wire holder. U	*	1	
34	G10-2-34	Wire holder. D	*	1	
35	G09-2-35	Washer	1	1	
36	G09-2-36	Felt	1	1	
37	G10-2-37	Screw	*	2	
38	G10-2-38	Spring	*	1	
39	G10-2-39	Tension release plate	*	1	
40	G10-2-40	Tension release pin	*	1	
41	G10-2-41	Retaining ring	*	1	
42	G09-2-42	Screw	1	1	
43	G09-2-43	Connect ru	1	1	
44	G09-2-44	Screw	3	3	
45	G09-2-45	Screw	3	3	
46	G09-2-46	Ground wire assy	1	1	
47	G09-2-47	Washer	1	1	
48	G09-2-48	Screw	1	1	
49	G09-2-49	Tension release supporting pin	1	1	
50	G09-2-50	Washer	2	2	

3. Presser foot mechanism

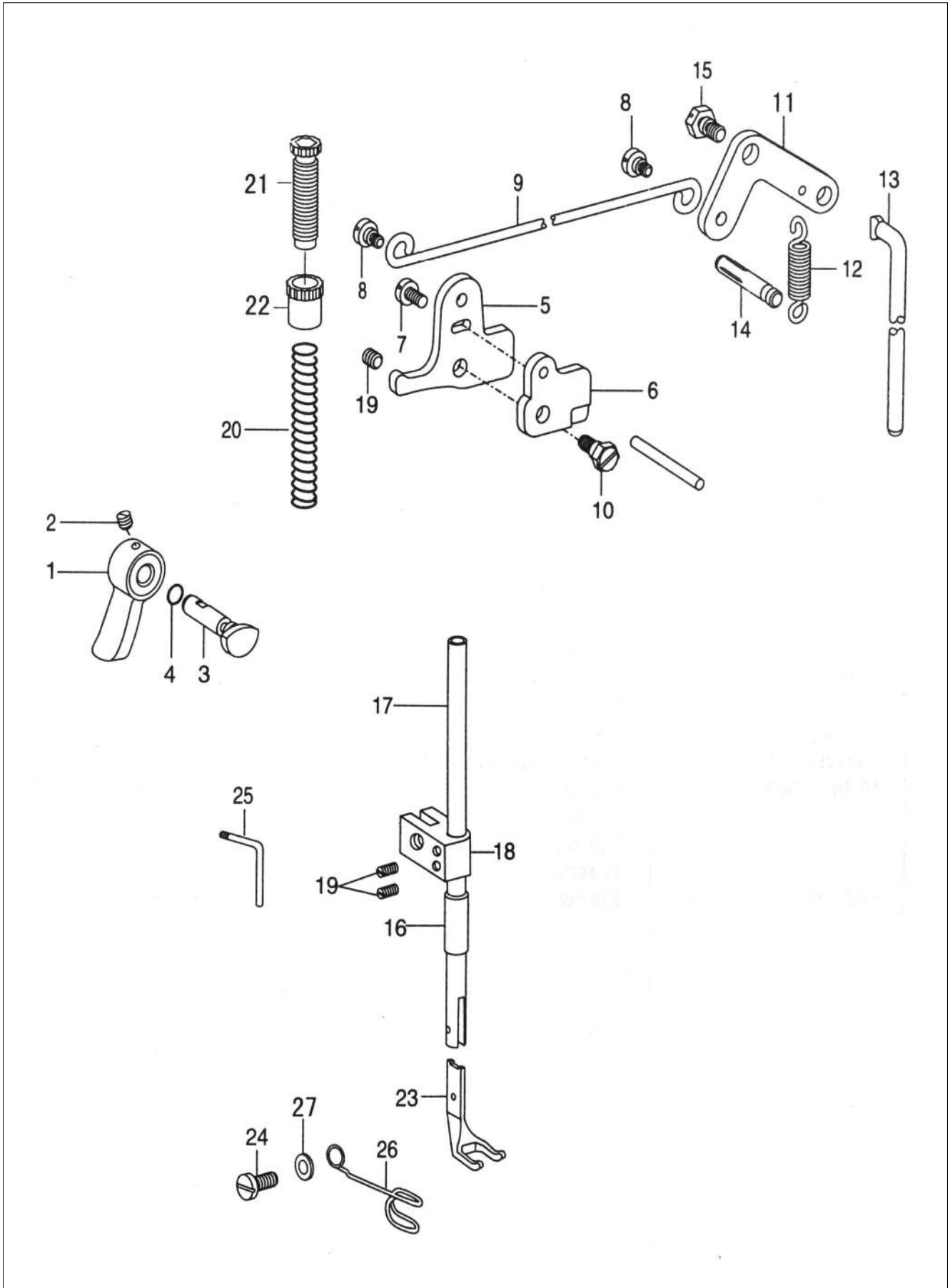

3. Presser foot mechanism

NO.	PartNumber	Name	Qty		Remark
			WF3955DD	WF3955AUT	
1	G09-3-1	Presser bar lifter	1	1	
2	G09-3-2	Screw	1	1	
3	G09-3-3	Lifter lever	1	1	
4	G09-3-4	O ring	1	1	GB3452.1 4.5x1.8G
5	G09-3-5	Lifter lever	1	1	
6	G09-3-6	Guide paate	1	1	
7	G09-3-7	Screw	1	1	
8	G09-3-8	Screw	2	2	
9	G09-3-9	Collecting rod	1	1	
10	G09-3-10	Screw	1	1	
11	G09-3-11	Lever	1	1	
12	G09-3-12	Spring, extension	1	1	
13	G09-3-13	Knee lifter bar	1	1	
14	G09-3-14	Spring hook	1	1	
15	G09-3-15	Shoulder screw	1	1	
16	G09-3-16	Bush	1	1	
17	G09-3-17	Presser bar	1	1	
18	G09-3-18	Guide bracket	1	1	
19	G09-3-19	Screw	2	2	
20	G09-3-20	Spring, compression	1	1	
21	G09-3-21	Adjusting screw, presser	1	1	
22	G09-3-22	Adjusting nut, presser	1	1	
23	G09-3-23	Presser foot, inside	1	1	
24	G09-3-24	Screw	1	1	
25	G09-3-25	Thrad guide	1	1	
26	G09-3-26	Finger guard	1	1	103940
27	G10-3-27	Washer	1	1	103680

4. Feed mechanism

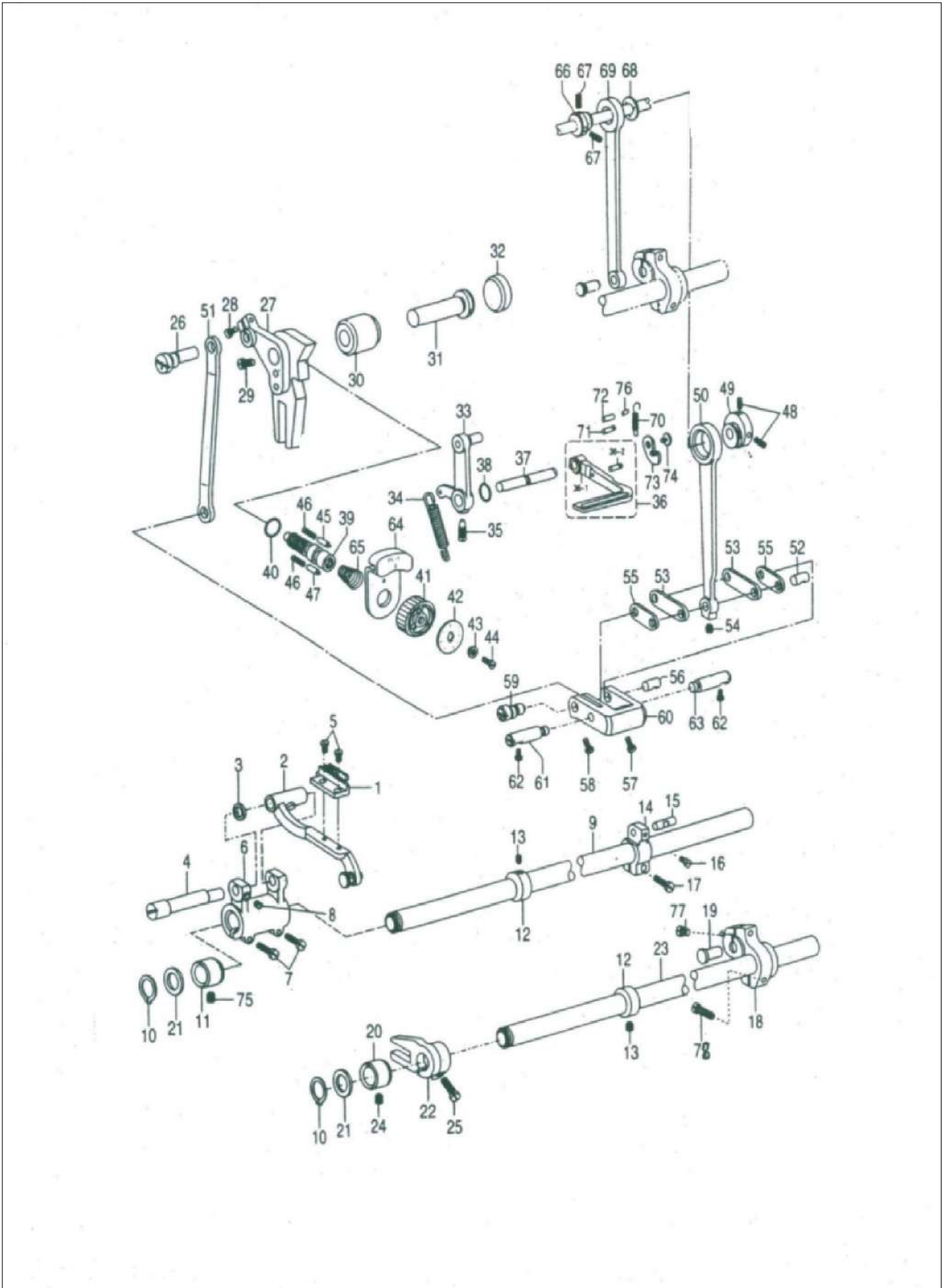

4. Feed mechanism

NO.	PartNumber	Name	Qty		Remark
			WF3955DD	WF3955AUT	
1	G09-4-1	Feed dog	1	1	GB894-86 15
2	G09-4-2	Feed bar	1	1	
3	G09-4-3	Washer	1	1	
4	G09-4-4	Shaft	1	1	
5	G09-4-5	Screw	2	2	
6	G09-4-6	Feed rock arm	1	1	
7	G09-4-7	Screw	2	2	
8	G09-4-8	Screw	1	1	
9	G09-4-9	Feed shaft	1	1	
10	G09-4-10	Retaining ring	2	2	
11	G09-4-11	Bush, L	2	2	
12	G09-4-12	Collar	2	2	
13	G09-4-13	Set screw	4	4	
14	G09-4-14	Feed rock arm	1	1	
15	G09-4-15	Stud	1	1	
16	G09-4-16	Set screw	1	1	
17	G09-4-17	Screw	1	1	
18	G09-4-18	Feed lifting arm	1	1	
19	G09-4-19	Pin	1	1	
20	G09-4-20	Bush, L	1	1	
21	G09-4-21	Washer	2	2	
22	G09-4-22	Feed lifting arm	1	1	
23	G09-4-23	Shaft	1	1	
24	G09-4-24	Screw	1	1	
25	G09-4-25	Screw	1	1	
26	G09-4-26	Connecting stud	1	1	
27	G09-4-27	Feed regulator	1	1	
28	G09-4-28	Screw, L	1	1	
29	G09-4-29	Screw, S	1	1	
30	G09-4-30	Bush	1	1	
31	G09-4-31	Shaft	1	1	
32	G09-4-32	Rubber cap	1	1	15.7
33	G09-4-33	Pin assy. lever	1	1	
34	G09-4-34	Spring, extension	1	1	
35	G09-4-35	Screw	1	1	
36	G09-4-36	Reverse stitching lever assy.	1	*	
	G10-4-36	Reverse stitching lever assy.	*	1	
(36-1)	G10-4-36-1	Reverse stitching lever	*	1	
(36-1)	G10-4-36-2	Spring hook pin	*	1	
37	G09-4-37	Shaft	1	*	
	G10-4-37	Shaft	*	1	

4. Feed mechanism

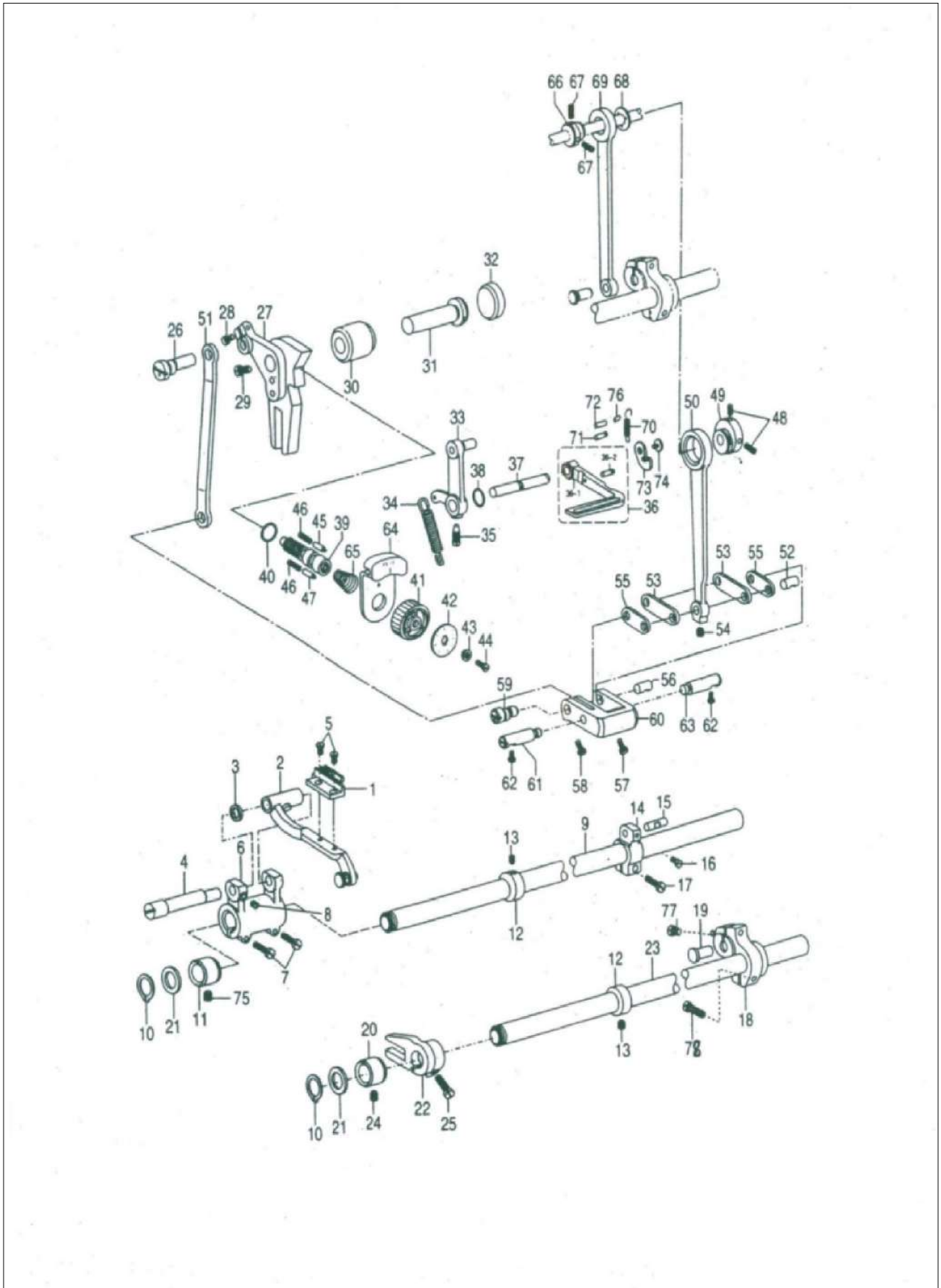

4. Feed mechanism

NO.	PartNumber	Name	Qty		Remark
			WF3955DD	WF3955AUT	
38	G09-4-38	O ring	2	2	GB1235 *1.9
39	G09-4-39	Adjusting screw	1	1	
40	G09-4-40	O ring	2	2	GB1235 4*2.4
41	G09-4-41	Stitch length dial	1	1	
42	G09-4-42	Stitch length plate	1	1	
43	G09-4-43	Support bush	1	1	
44	G09-4-44	Screw	1	1	
45	G09-4-45	Positioning pin	1	1	
46	G09-4-46	Spring	2	2	
47	G09-4-47	Stopper pin	1	1	
48	G09-4-48	Set screw	3	3	
49	G09-4-49	Feed cam	1	1	
50	G09-4-50	Feed connecting rod	1	1	
51	G09-4-51	Connecting rod	1	1	
52	G09-4-52	Stud	1	1	
53	G09-4-53	Link	2	2	
54	G09-4-54	Set screw	1	1	
55	G09-4-55	Link	2	2	
56	G09-4-56	Shaft	1	1	
57	G09-4-57	Screw	1	1	
58	G09-4-58	Screw	1	1	
59	G09-4-59	Shaft	1	1	
60	G09-4-60	Feed regulator crank	1	1	
61	G09-4-61	Pin shaft.L	1	1	
62	G09-4-62	Screw	1	1	
63	G09-4-63	Pin shaft.R	1	1	
64	G09-4-64	Stopper	1	1	
65	G09-4-65	Spring	1	1	
66	G09-4-66	Eccentric wheel	1	1	
67	G09-4-67	Screw	3	3	
68	G09-4-68	Holder	1	1	
69	G09-4-69	Feed lifting rod	1	1	
70	G10-4-70	Spring	*	1	
71	G10-4-71	Spring hook	*	1	
72	G10-4-72	Pin	*	1	
73	G10-4-73	Plate	*	1	
74	G10-4-74	Screw	*	1	
75	G09-4-75	Screw	1	1	
76	G10-4-76	Pin shaft	*	1	
77	G09-4-77	Screw	1	1	
78	G09-4-78	Screw	*	*	
79	G09-4-79	Screw	*	*	
80	G09-4-80	Screw	1	1	

5. Upper feed mechanism

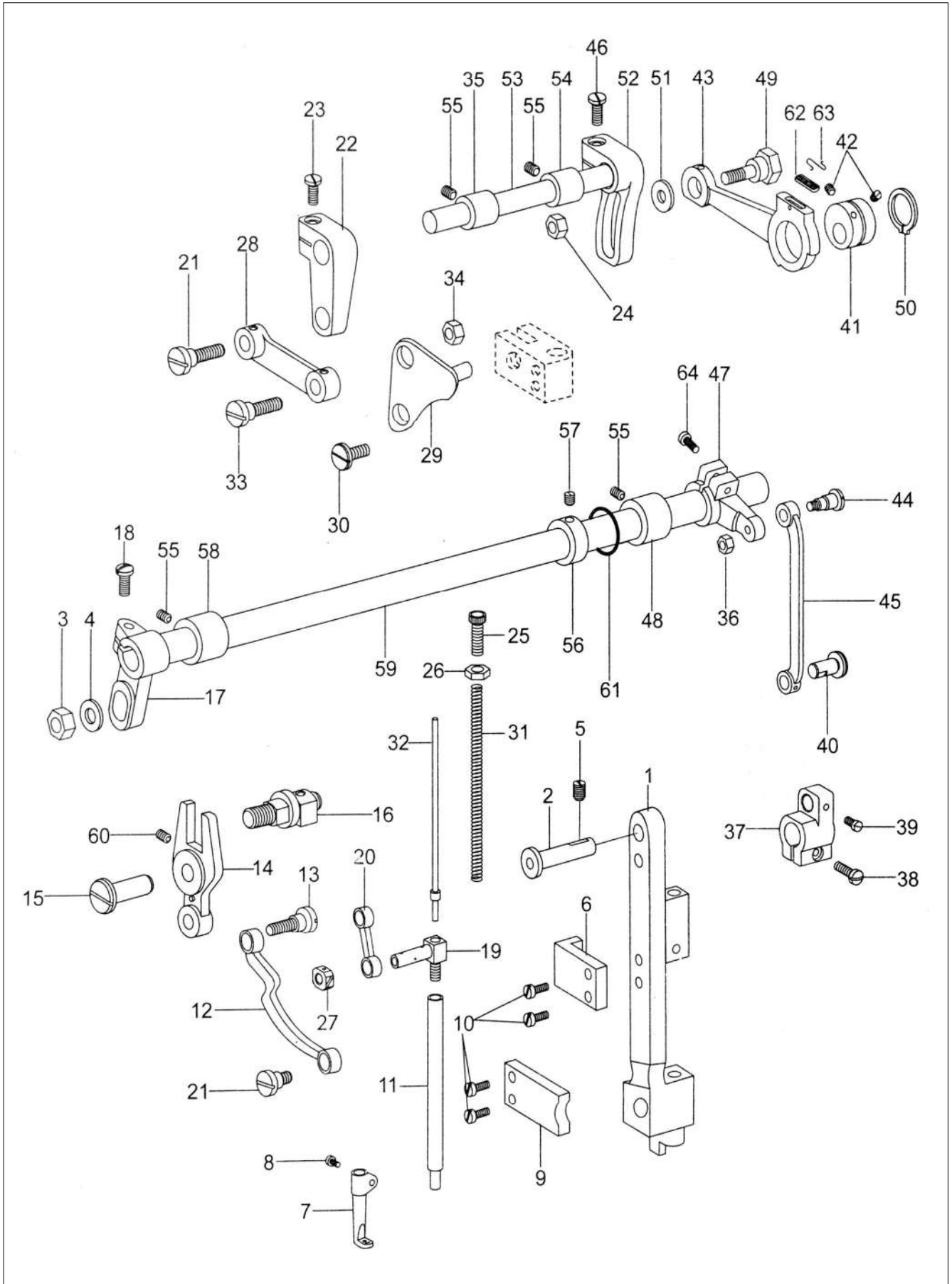

5. Upper feed mechanism

NO.	PartNumber	Name	Qty		Remark
			WF3955DD	WF3955AUT	
1	G09-5-1	Needle bar rocking frame	1	1	6GB95 6
2	G09-5-2	Shaft, n/b rocking frame	1	1	
3	G09-5-3	Nut	1	1	
4	G09-5-4	Washer	1	1	
5	G09-5-5	Screw	1	1	
6	G09-5-6	Guider	1	1	
7	G09-5-7	Walking foot	1	1	
8	G09-5-8	Screw	1	1	
9	G09-5-9	Block	1	1	
10	G09-5-10	Screw	4	4	
11	G09-5-11	Presser bar, walking foot	1	1	
12	G09-5-12	Link	1	1	
13	G09-5-13	Screw	1	1	
14	G09-5-14	Crank	1	1	
15	G09-5-15	Pin shaft	1	1	
16	G09-5-16	Stud shaft assy.	1	1	
17	G09-5-17	Feed rocking arm crank, L	1	1	
18	G09-5-18	Screw	2	2	
19	G09-5-19	Connector	1	1	
20	G09-5-20	Link	1	1	
21	G09-5-21	Screw	2	2	
22	G09-5-22	Feed lifting arm crank, L	1	1	
23	G09-5-23	Screw	1	1	
24	G09-5-24	Nut	1	1	
25	G09-5-25	Screw	1	1	
26	G09-5-26	Nut	1	2	
27	G09-5-27	Block	1	1	
28	G09-5-28	Link	1	1	
29	G09-5-29	Crank	1	2	
30	G09-5-30	Stud	1	1	
31	G09-5-31	Spring, compression	1	1	
32	G09-5-32	Guide bar	1	1	
33	G09-5-33	Screw	1	*	
34	G09-5-34	Nut	1	1	
35	G09-5-35	Bush, L	1	1	
36	G09-5-36	Nut	1	1	
37	G09-5-37	Feed rocker arm	1	1	
38	G09-5-38	Screw	1	1	
39	G09-5-39	Set screw	1	1	
40	G09-5-40	Stud	1	1	
41	G09-5-41	Eccentric wheel	1	1	
42	G09-5-42	Screw	2	2	
43	G09-5-43	Connecting rod	1	1	
44	G09-5-44	Shoulder screw	1	1	
45	G09-5-45	Connecting rod	1	1	
46	G09-5-46	Shoulder screw	1	1	
47	G09-5-47	Feed rocking arm crank, R	1	1	
48	G09-5-48	Bush, M	1	1	
49	G09-5-49	Screw	1	1	
50	G09-5-50	Retaining ring, C	1	1	GB894. 1 25
51	G09-5-51	Washer	1	1	
52	G09-5-52	Feed arm	1	1	
53	G09-5-53	Feed lifting shaft	1	1	
54	G09-5-54	Bush, R	1	1	
55	G09-5-55	Screw	3	3	
56	G09-5-56	Collar	1	1	
57	G09-5-57	Screw	2	2	
58	G09-5-58	Bush, L	1	1	
59	G09-5-59	Upper feed shaft	1	1	
60	G09-5-60	Screw	1	1	
61	G09-5-61	O ring	1	1	
62	G09-5-62	Oil felt	1	1	
63	G09-5-63	Spring	1	1	
64	G09-5-64	Screw	1	1	

6. Hook mechanism

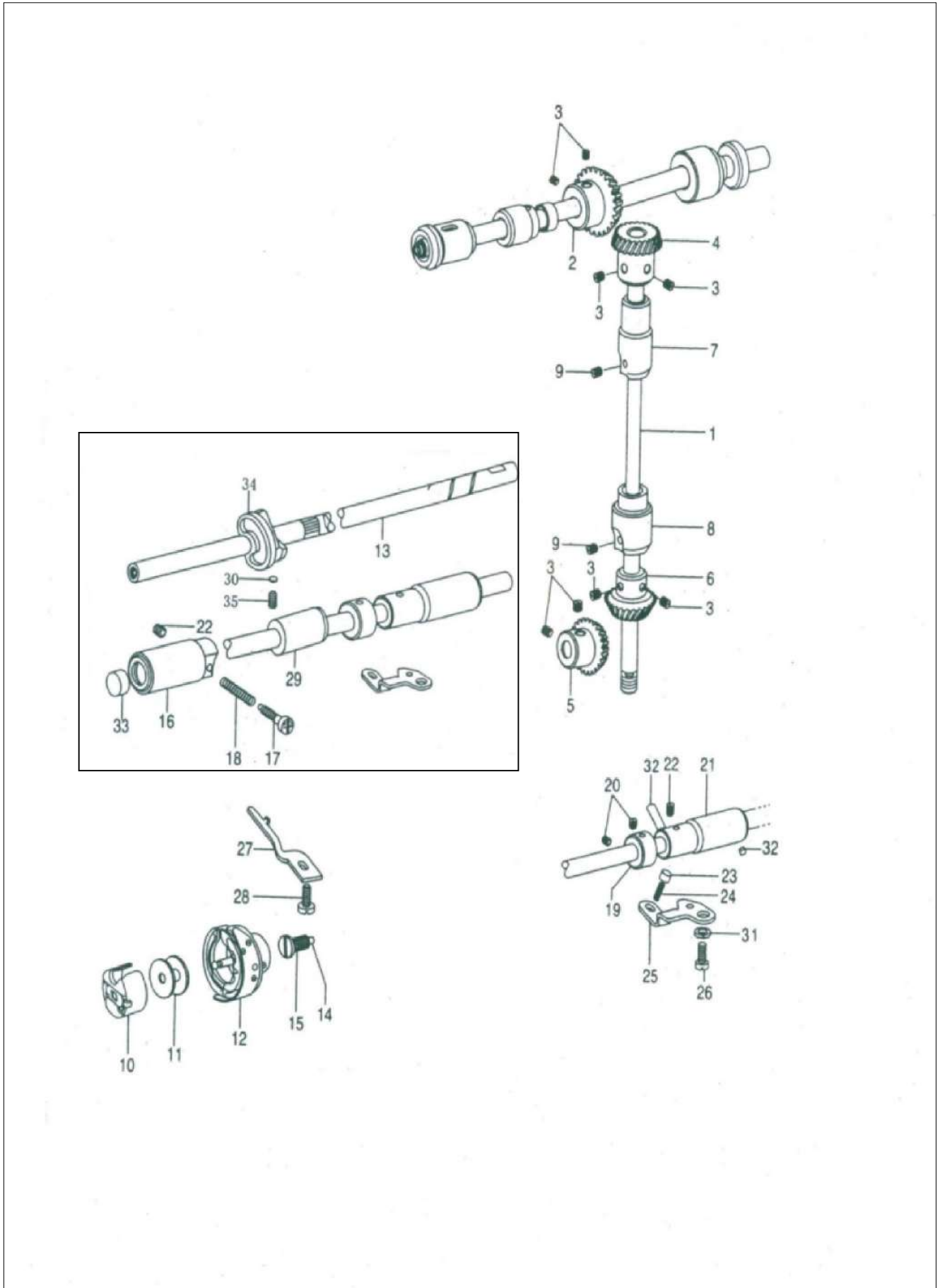

6. Hook mechanism

NO.	PartNumber	Name	Qty		Remark
			WF3955DD	WF3955AUT	
1	G09-6-1	Vertical shaft	1	1	
2	G09-6-2	Bevel gear, upper shaft	1	1	
3	G09-6-3	Set screw	8	8	
4	G09-6-4	Bevel gear, vertical shaft, U	1	1	
5	G09-6-5	Bevel gear, lower shaft	1	1	
6	G09-6-6	Bevel gear, vertical shaft, L	1	1	
7	G09-6-7	Bush, vertical shaft, U	1	1	
8	G09-6-8	Bush, vertical shaft, L	1	1	
9	G09-6-9	Screw	2	2	
10	G09-6-10	Bobbin case	1	*	
	G09-6-11	Bobbin case	*	1	
11	G09-6-12	Bobbin	1	*	
	G10-6-11	Bobbin	*	1	
12	G09-6-12	Hook assy.	1	*	
	G10-6-12	Hook assy.	*	1	
13	G09-6-13	Lower shaft	1	*	
	G10-6-13	Lower shaft	*	1	
14	G09-6-14	Filter	1	1	
15	G09-6-15	Screw	1	1	
16	G09-6-16	Bush, lower shaft, L	1	*	
	G10-6-16	Bush, lower shaft, L	*	1	
17	G09-6-17	Adjusting screw, oil	1	1	
18	G09-6-18	Adjusting screw	1	1	
19	G09-6-19	Collar	1	1	
20	G09-6-20	Screw	2	2	
21	G09-6-21	Bush, lower shaft, R	1	1	
22	G09-6-22	Screw	2	2	
23	G09-6-23	Plunger	1	1	
24	G09-6-24	Spring	1	1	
25	G09-6-25	Hold plat	1	1	
26	G09-6-26	Screw	1	1	
27	G09-6-27	B/case holder position bracket	1	1	
28	G09-6-28	Screw	1	1	
29	G09-6-29	Bush, lower shaft, M	*	1	
30	G09-6-30	Holder plate	*	2	
31	G09-6-31	Washer	1	1	GB93 6
32	G09-6-32	Oil seal	1	1	
33	G09-6-33	Oil seal	1	*	
	G10-6-33	Oil seal	*	1	
34	G10-6-34	Trimmer driving com	*	1	
35	G10-6-35	Screw	*	2	

7. Lubrication mechanism

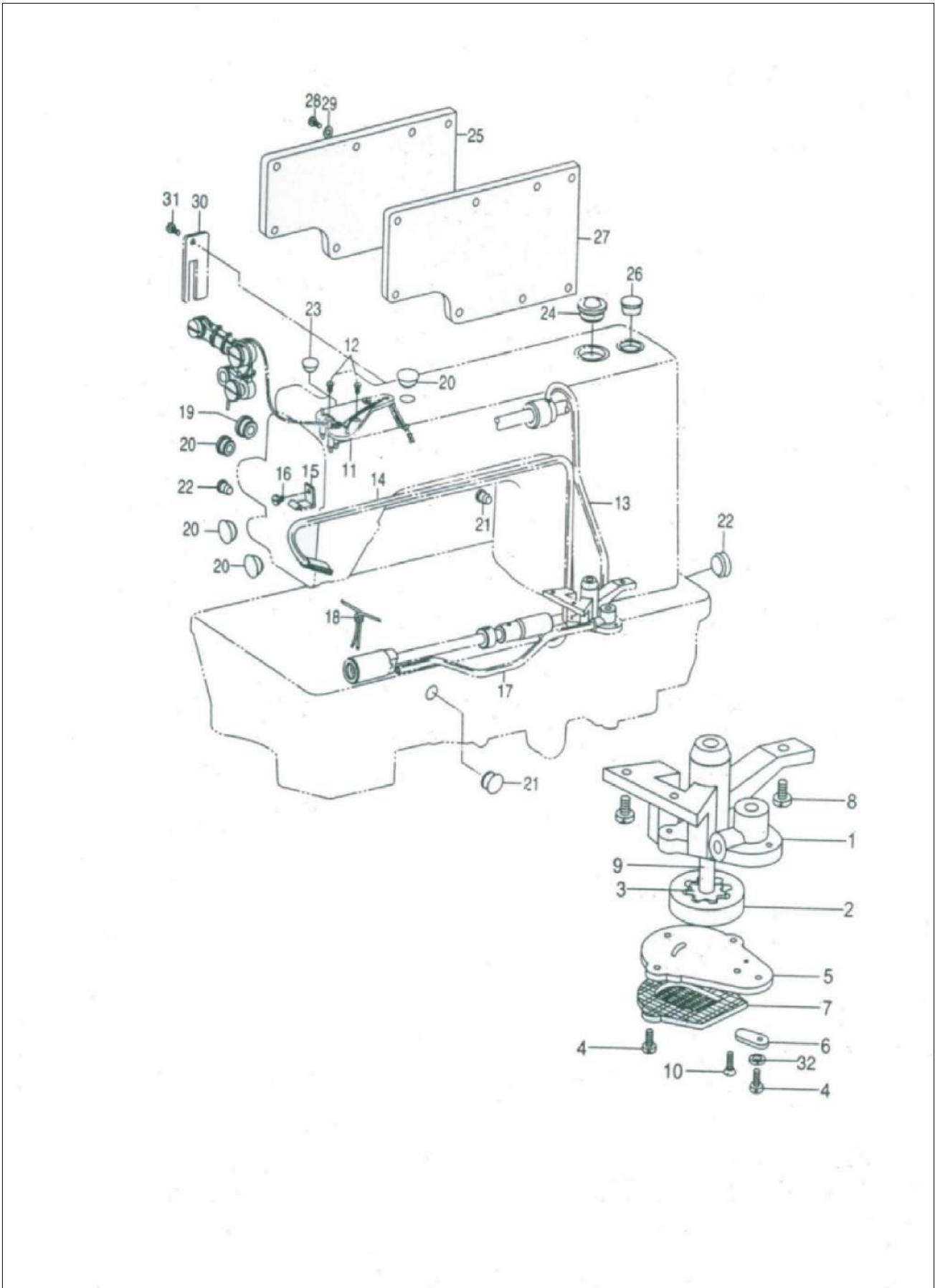

7. Lubrication mechanism

NO.	PartNumber	Name	Qty		Remark
			WF3955DD	WF3955AUT	
1	G09-7-1	Pump body	1	1	
2	G09-7-2	Big gear, pump	1	1	
3	G09-7-3	Smallgear, pump	1	1	
4	G09-7-4	Screw	3	3	
5	G09-7-5	Cover	1	1	
6	G09-7-6	Throat plate	1	1	
7	G09-7-7	Filter ser	1	1	
8	G09-7-8	Screw	3	3	
9	G09-7-9	Shaft	1	1	
10	G09-7-10	Screw	2	2	
11	G09-7-11	Setting plate	1	1	
12	G09-7-12	Screw	2	2	
13	G09-7-13	Oil seal	1	1	
14	G09-7-14	Tube assy	1	1	
15	G09-7-15	Holder	1	1	
16	G09-7-16	Screw	1	1	
17	G09-7-17	Oil tube, L	1	*	
	G10-7-17	Oil tube, L	*	1	
18	G09-7-18	Oil wick	1	1	Φ 19
19	G09-7-19	Rubber cap	4	4	Φ 11.8
20	G09-7-20	Rubber cap	2	2	Φ 8.8
21	G09-7-21	Rubber cap	1	1	Φ 27
22	G09-7-22	Rubber cap	1	1	Φ 5.7
23	G09-7-23	Rubber cap	1	1	
24	G09-7-24	Oil gauge window	1	1	
25	G09-7-25	Back cover	1	1	
26	G09-7-26	Rubber cap	1	1	Φ 25.5
27	G09-7-27	Packing	1	1	
28	G09-7-28	Screw	9	9	
29	G09-7-29	Washer	9	9	
30	G09-7-30	Oil pan	1	1	
31	G09-7-31	Screw	1	1	
32	G09-7-32	Washer, spring	1	1	

8. Thread trimming mechanism(3955AUT)

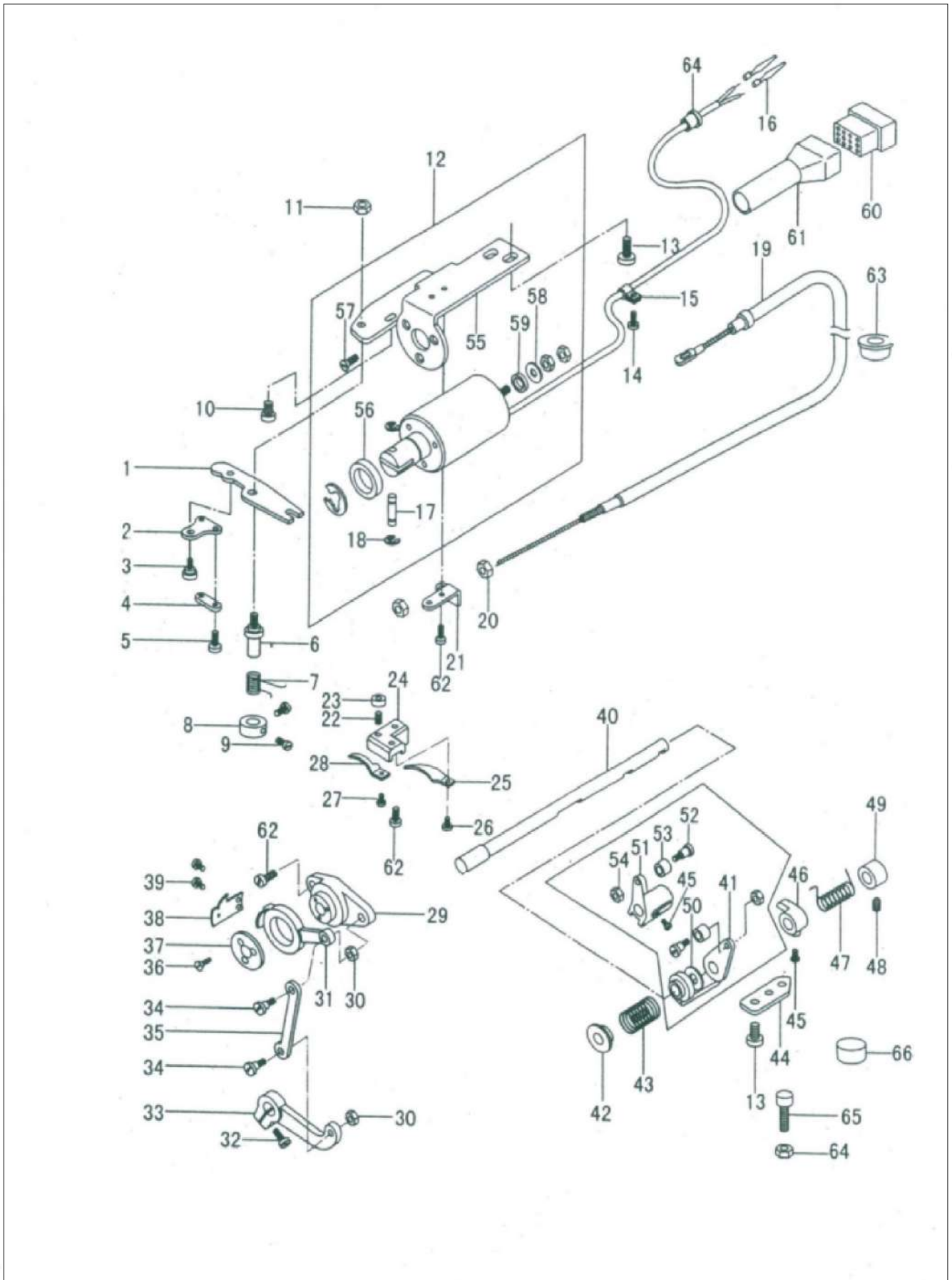

8. Thread trimming mechanism (3955AUT)

NO.	PartNumber	Name	Qty		Remark
			WF3955DD	WF3955AUT	
1	G10-8-1	Driven plate	*	1	
2	G10-8-2	Wire support	*	1	
3	G10-8-3	Screw	*	1	
4	G10-8-4	Link	*	1	
5	G10-8-5	Screw	*	1	
6	G10-8-6	Screw pin, driven plate	*	1	
7	G10-8-7	Spring	*	1	
8	G10-8-8	Collar	*	1	
9	G10-8-9	Screw	*	2	
10	G10-8-10	Screw	*	1	
11	G10-8-11	Nut	*	1	
12	G10-8-12	Thread trimmer solenoid assy	*	1	
13	G10-8-13	Screw	*	4	
14	G10-8-14	Screw	*	1	
15	G10-8-15	Wire holder	*	1	
16	G10-8-16	Terminal pin	*	2	
17	G10-8-17	Pin	*	1	
18	G10-8-18	Retaining ring	*	2	
19	G10-8-19	Tension release wire	*	1	
20	G10-8-20	Nut	*	2	
21	G10-8-21	Tension release lever	*	1	
22	G10-8-22	Screw	*	1	
23	G10-8-23	Nut	*	1	
24	G10-8-24	Holder, F-knife	*	1	
25	G10-8-25	Lower thread finger	*	1	
26	G10-8-26	Screw	*	1	
27	G10-8-27	Screw	*	1	
28	G10-8-28	Fixed knife	*	1	
29	G10-8-29	Holder, M-knife	*	1	
30	G10-8-30	Nut	*	2	
31	G10-8-31	Holder, M-knife, L	*	1	
32	G10-8-32	Screw	*	1	
33	G10-8-33	Driven crank	*	1	
34	G10-8-34	Screw	*	2	
35	G10-8-35	Link	*	1	
36	G10-8-36	Screw	*	3	

8. Thread trimming mechanism(3955AUT)

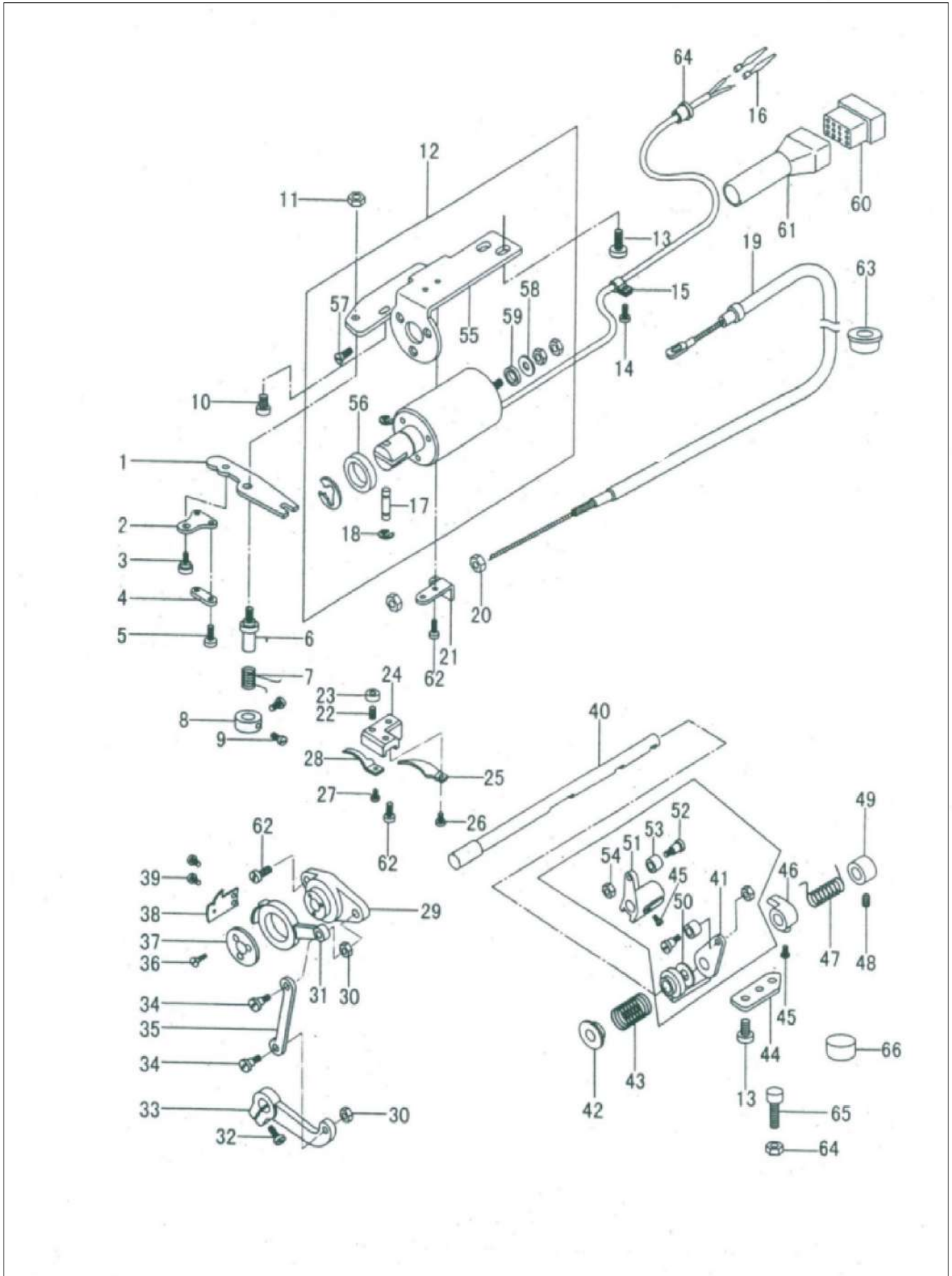

8. Thread trimming mechanism(3955AUT)

NO.	PartNumber	Name	Qty		Remark
			WF3955DD	WF3955AUT	
37	G10-8-37	Washer	*	1	
38	G10-8-38	Movable knife	*	1	
39	G10-8-39	Screw	*	2	
40	G10-8-40	Thread trimmer cam lever shaft	*	1	
41	G10-8-41	Thread trimmer cam lever,R	*	1	
42	G10-8-42	Collar	*	1	
43	G10-8-43	Spring	*	1	
44	G10-8-44	Stopper plate	*	1	
45	G10-8-45	Screw	*	3	
46	G10-8-46	Positioning block	*	1	
47	G10-8-47	Spring	*	1	
48	G10-8-48	Screw	*	2	
49	G10-8-49	Collar	*	1	
50	G10-8-50	Plastic ring	*	1	
51	G10-8-51	Thread trimmer cam lever,L	*	1	
52	G10-8-52	Screw	*	2	
53	G10-8-53	Roller	*	2	
54	G10-8-54	Nut	*	2	
55	G10-8-55	Thread trimmer solenoid base	*	1	
56	G10-8-56	Seal washer, big	*	1	
57	G10-8-57	Screw	*	3	
58	G10-8-58	Washer	*	1	
59	G10-8-59	Seal washer, small	*	1	
60	G10-8-60	Connector	*	1	
61	G10-8-61	Cover	*	1	
62	G10-8-62	Screw	*	4	
63	G10-8-63	Guard	*	1	
64	G10-8-64	Nut	*	1	
65	G10-8-65	Screw	*	1	
66	G10-8-66	Packing	*	1	

9. Revere stitching mechanism(3995AUT)

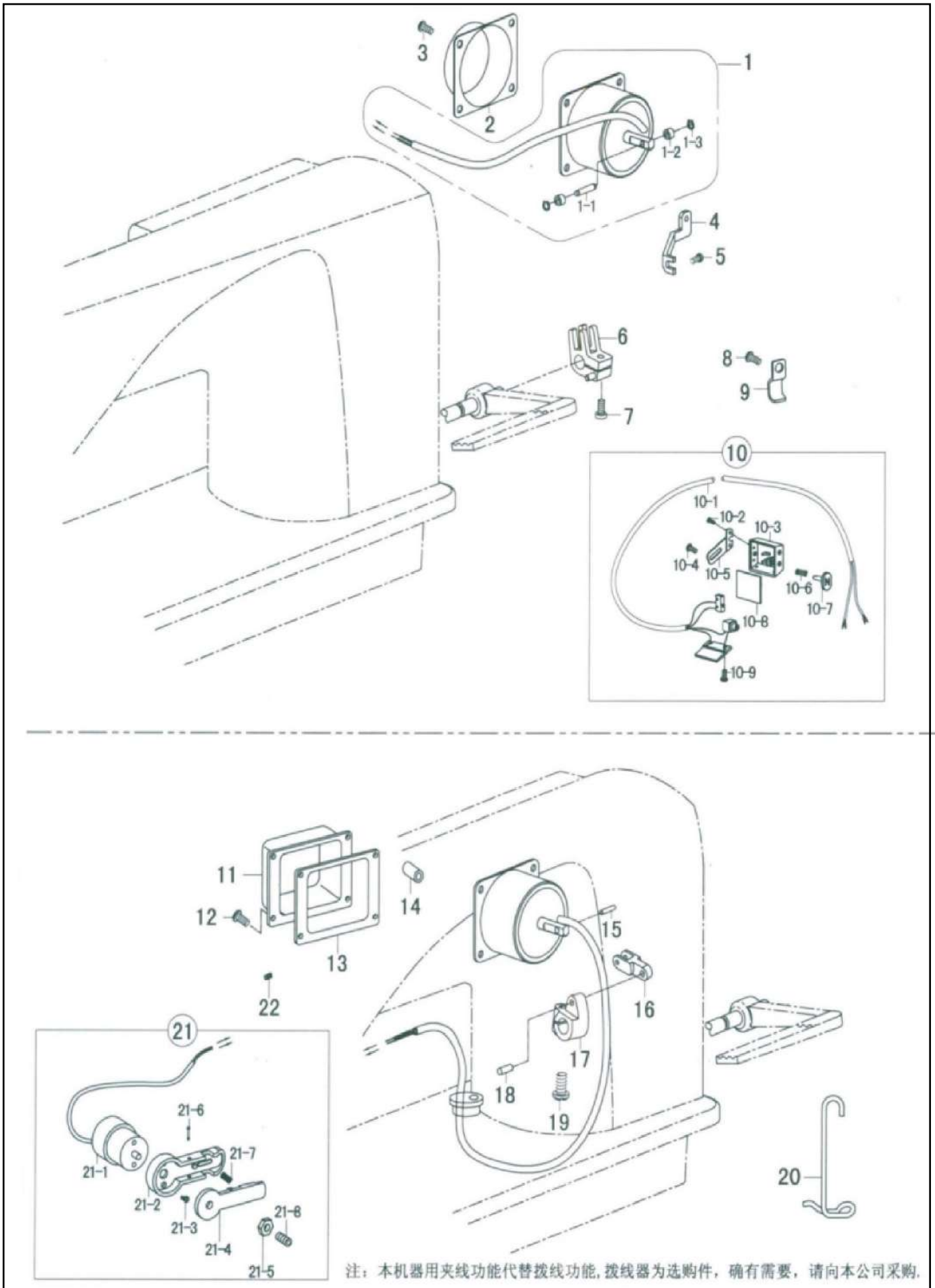

9. Reverse stitching mechanism(3955AUT)

NO.	PartNumber	Name	Qty		Remark
			WF3955DD	WF3955AUT	
1	G10-9-1	Peverse feed asm	*	1	
(1-1)	G10-9-1-1	Plunger arm pin	*	1	
(1-2)	G10-9-1-2	Collar	*	2	
(1-3)	G10-9-1-3	E-ring	*	2	
2	G10-9-2	Cover	*	1	
3	G10-9-3	Screw	*	3	
4	G10-9-4	Bracket	*	1	
5	G10-9-5	Screw	*	1	
6	G10-9-6	Crank	*	1	
7	G10-9-7	Screw	*	1	
8	G10-9-8	Screw	*	2	
9	G10-9-9	Cord holder	*	2	
10	G10-9-10	Wire,reverse solenoid	*	1	
(10-1)	G10-9-10-1	Reverse switch assy	*	1	
(10-2)	G10-9-10-2	Screw	*	2	
(10-3)	G10-9-10-3	Support	*	1	
(10-4)	G10-9-10-4	Screw	*	2	
(10-5)	G10-9-10-5	Bracket	*	1	
(10-6)	G10-9-10-6	Spring	*	1	
(10-7)	G10-9-10-7	Actuator	*	1	
(10-8)	G10-9-10-8	Baffle	*	1	
(10-9)	G10-9-10-9	Screw	*	2	
11	G10-9-11	Solenoid cover	*	1	
12	G10-9-12	Screw	*	1	
13	G10-9-13	Washer	*	1	
14	G10-9-14	Space collar	*	1	
15	G10-9-15	Pin	*	1	
16	G10-9-16	Connecting lever	*	1	
17	G10-9-17	Solenoid lever	*	1	
18	G10-9-18	Pin	*	1	
19	G10-9-19	Screw	*	1	
20	G10-9-20	Cord holder	*	1	
21	G10-9-21	Clip wire Electromagnet asm	*	1	
(21-1)	G10-9-21-1	Electromagnet	*	1	
(21-2)	G10-9-21-2	The bottom plate	*	1	
(21-3)	G10-9-21-3	Screw	*	2	
(21-4)	G10-9-21-4	Plate	*	1	
(21-5)	G10-9-21-5	Nut	*	1	
(21-6)	G10-9-21-6	Screw	*	1	
(21-7)	G10-9-21-7	Spring	*	1	
(21-8)	G10-9-21-8	Screw	*	1	
22	G10-9-22	Screw	*	1	

10. Accessories for model

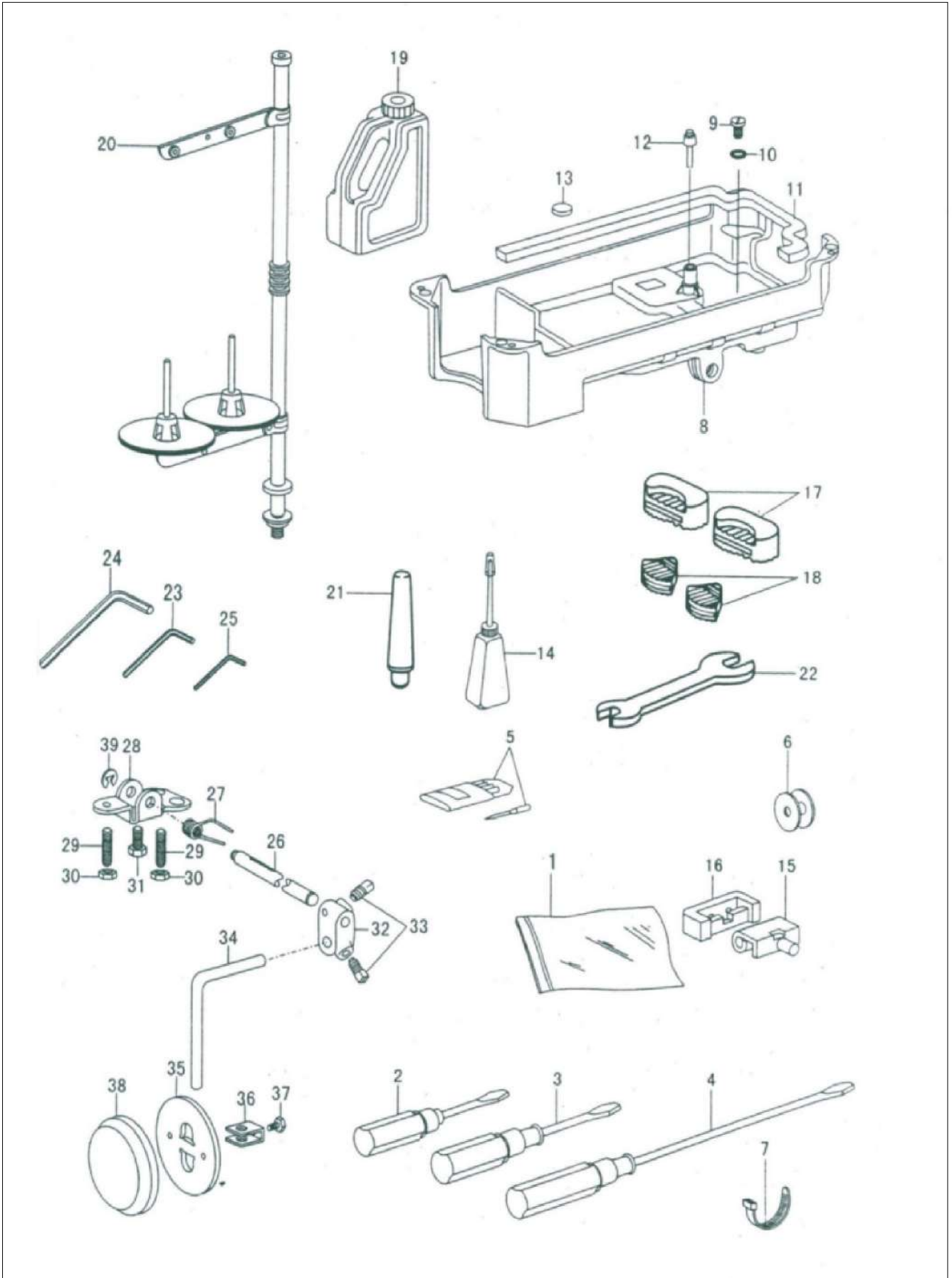

10. Accessories for model

NO.	PartNumber	Name	Qty		Remark
			WF3955DD	WF3955AUT	
1	G09-10-1	Accessory bag	1	1	
2	G09-10-2	Screw driver, S	1	1	
3	G09-10-3	Screw driver, M	1	1	
4	G09-10-4	Screw driver, L	1	1	
5	G09-10-5	Needle	1	1	DP*17 23#
6	G09-10-6	Bobbin	3	*	
	G10-10-6	Bobbin	*	3	
7	G09-10-7	Tie	3	3	
8	G09-10-8	Oil pan	1	1	
9	G09-10-9	Screw	1	1	
10	G09-10-10	Washer	1	1	
11	G09-10-11	Pad	1	1	
12	G09-10-12	Bar	1	1	
13	G09-10-13	Magnet	1	1	
14	G09-10-14	Oil pot	1	1	
15	G09-10-15	Head hinge	2	2	
16	G09-10-16	Cushion, head hinge	2	2	
17	G09-10-17	Head cushion, L	2	2	
18	G09-10-18	Head cushion, S	2	2	
19	G09-10-19	Oil tank	1	1	
20	G09-10-20	Thread stand assy	1	1	
21	G09-10-21	Head rest	1	1	
22	G09-10-22	Wrench	1	1	
23	G09-10-23	Wrench, 2mm	1	1	2GB/T5356-1998
24	G09-10-24	Wrench, 3mm	1	1	3GB/T5356-1998
25	G09-10-25	Wrench, 2.5mm	1	1	2.58GB/T5356-1998
26	G09-10-26	Lifter shaft	1	1	
27	G09-10-27	Spring	1	1	
28	G09-10-28	Bracket	1	1	
29	G09-10-29	Adjusting screw	2	2	
30	G09-10-30	Adjusting nut	2	2	
31	G09-10-31	Screw	1	1	
32	G09-10-32	Bracket	1	1	
33	G09-10-33	Screw	1	1	GB/T5781 MX12
34	G09-10-34	Lifter bar	1	1	
35	G09-10-35	Knee lifter plate	1	1	
36	G09-10-36	Stopper	1	1	
37	G09-10-37	Screw	1	1	
38	G09-10-38	Cover, K-lifter plate	1	1	
39	G09-10-39	Retaining ring	1	1	GB/896 9

GLOBAL
